

CB1003-1607



ZGCC

工程截齿

ENGINEERING AND MINING TOOLS



自贡硬质合金有限责任公司
ZIGONG CEMENTED CARBIDE CORP CO.,LTD.

地 址：中国四川自贡市板仓工业区富川路
Add: Fuchuan Road, Bancang Industrial Park, Zigong Sichuan, China
邮 编 P.C: 643000
网 址 <http://www.zgcc.com>
销售电话 Sales Tel. :
(0813)5516685 5516690 5516232 5516080
传 真 Fax: (0813)5516080



自贡硬质合金有限责任公司
ZIGONG CEMENTED CARBIDE CORP CO.,LTD.



品质成就未来

QUALITY ACCOMPLISHES THE FUTURE

自贡硬质合金有限责任公司

- 世界500强企业中国五矿集团的核心成员
- 中国第一家自主设计建设的大型硬质合金企业
- 国内领先的硬质合金及配套工具制造商
- 世界先进水平的硬面材料及其应用服务提供者
- 国内领先的钨钼制品制造商

ZIGONG CEMENTED CARBIDE CO., LTD.

- Zigong Cemented Carbide Co., Ltd (ZGCC) is a core member of China Minmetals Group which is one of the world 500 top companies.
- ZGCC is the first home-designed and built large scale cemented carbide manufacturing enterprise in China.
- It is one of the leading manufacturers of cemented carbides and related tools at home.
- It is a reliable supplier of the hard-facing materials with advanced world levels and their application services.
- It holds the leadership position in the tungsten and molybdenum product manufacture in China.



我们的优势

Our superiority

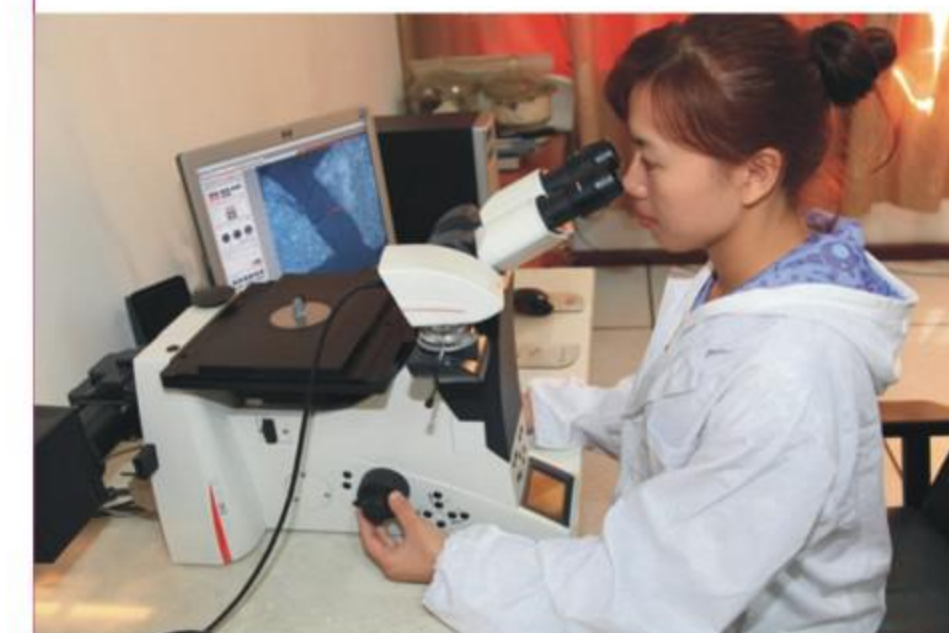

- 50年专注于专业领域的持续努力
- 高品质、专业化，产品系列丰富
- 国家级高新技术企业、设有博士后科研工作站
- 致力于不断寻找新的材质以提高产品性能、新的加工方法以提高加工效率和灵活度

- ZGCC has been concentrating on the specialized fields for 50 years.
- The products are of top quality. Standardized and customized products in various grades and types are available.
- ZGCC is a state-rank high tech company, having a postdoctoral scientific research workstation.
- Sparring no efforts to develop and seek for new materials to improve product quality and new processing methods to maximize machining practice.

目录

企业资质	02
长城牌硬质合金/工程截齿	03
合金齿选择指南	04
截齿选择指南	05
锥形截齿 柄部直径 Φ 22mm	07
锥形截齿 柄部直径 Φ 25mm	07
锥形截齿 柄部直径 Φ 30mm	09
锥形截齿 柄部直径 Φ 34mm	11
锥形截齿 柄部直径 Φ 35mm	12
锥形截齿 柄部直径 Φ 38mm	13
锥形截齿 柄部直径 Φ 38 \times 30mm	14
锥形截齿 柄部直径 Φ 43 \times 35mm	16
扁形截齿	17





■ 自贡硬质合金有限责任公司是中国第一家自主设计建设的大型硬质合金企业，是国内领先的硬质合金及配套工具供应商。“长城牌”硬质合金及工具广泛应用于机械、冶金、石油、矿山、建筑、电子、航天航空、路面工程等领域。

公司技术力量雄厚，注重技术与管理创新，建有博士后科研工作站和省级技术中心，属四川省高新技术企业、四川省“技术创新试点示范企业”。近年来，公司以“技术中心”、“博士后科研工作站”为平台，先后与中南大学、国防科技大学、华中理工大学、武汉理工大学、哈尔滨理工大学、重庆大学、四川大学、昆明理工大学、美国犹他大学等国内外10多个高等院校、科研机构开展了科研项目、技术人员培养等方面的合作，富有成效，推进了公司的技术进步。近年来，公司申请专利70余项，取得国家、省部级科技成果40余项。公司凭借品质与服务优良，技术与管理领先，获得了“全国用户满意产品”、“中国名牌产品”、“中国驰名商标”，以及“全国用户满意企业”、“国家质量管理奖”、“全国质量管理先进企业”称号。

■ 自贡硬质合金有限责任公司生产适用于各种型号的采煤机用镐形截齿、扁形截齿、掘进机用掘进截齿、旋挖钻机用旋挖截齿等。产品广泛用于矿山长臂采矿、连续采矿、工程掘沟、复垦、桩孔施工等领域。产品遵循一流的质量标准、采用优质的材料，按照先进的工艺流程进行制造生产，为客户提供高品质的截齿工具。

自贡硬质合金有限责任公司是国内领先的硬质合金及工具配套供应商。我们将严格遵循生产工艺，确保每一颗用在“长城”牌截齿上的硬质合金满足您的要求。生产过程中所采用的先进处理方法使得硬质合金的硬度、强度和钎焊性能达到最佳。硬质合金和优质合金钢结合采用先进的钎焊和热处理技术，带来截齿工具出众的优质表现。



合金齿选择指南



▶ 柱形合金齿 (Z型)



柱形硬质合金齿采用传统的孔、柱钎焊连接方式，适用截齿主体部分工作磨损不明显的各类工况。此类合金齿适用于硬及高冲击条件。

▶ 帽形合金齿 (M型)



帽形硬质合金齿采用阀座式的钎焊连接方式，能够有效的增加焊接强度和抗剪性能。帽形合金齿能够提供出色的渗透性，宽大的肩部设计为抵抗截齿主体磨损带来卓越的保护。此类合金适用于软到中硬冲击条件。

▶ 蘑菇形合金齿 (G型)



蘑菇形合金采用变径设计，结合了柱形合金和帽形合金的特点，可以有效保护钎焊接头，延缓钢体磨损。适用于钢体磨损严重工况。

▶ 复合合金 (X型)



复合合金头部更尖锐，穿透性好；肩部宽大，可以更好地保护钢体；底部锥形设计强度更高。适用于各种工况。

截齿选择指南



柄部直径	型号	工况			合金				支/盒
		软	中	硬	柱型	帽型	蘑菇头	复合	
22mm	HV2244M1617Z	●				●			40
	HV2244M1617ZC	●				●			40
	HV2237M1614Z	●				●			40
	HV2245P2519Z	●							40
25mm	HV2563M2524Z	●				●			35
	HV2561Z1219Z	●			●				30
	HV2562Z1624Z	●			●				30
	HV2558Z1217X	●			●				20
	HV2558Z1322X	●			●				20
	HV2567Z2235D			●	●				15
	HV2565M2524D		●			●			15
HV2567M2932D			●		●			15	
30mm	HV120-19G	●					●		15
	HV120-22G		●				●		15
	HV120-1824	●			●				10
	HV120-1929		●		●				10
	HV120-2230			●	●				10
	HV120-22GH		●				●		10
	HV120-2535H			●	●				10
	HV82-14G	●					●		15
	HV82-16G	●					●		15
	HV84-20XH		●					●	15
	HV62-1622	●			●				15
	HV84-1829		●		●				15
	HV84-19G		●				●		15
34mm	HV100-19G			●			●		15
	HV100-22G			●			●		15
35mm	HV92-16G	●					●		10
	HV94-19G	●					●		10
	HV94-1925	●			●				10
	HV95-2535H		●		●				10
	HV95-29XH			●				●	10
	HV95-2535			●	●				10



柄部直径	型号	工况			合金				支/盒
		软	中	硬	柱型	帽型	蘑菇头	复合	
38mm	HV135-22G		●				●		10
	HV135-25G			●			●		10
	HV135M-29XH		●					●	6
	HV135-2535			●	●				10
	HV135M-3038H			●	●				6
	HVRC38-30			●	●				6
	HVRC38-34			●	●				6
	HV135-2535T			●	●				10
38 × 30mm	HV3050-1824	●			●				15
	HV3050-1829	●			●				15
	HV3050-1925		●		●				15
	HV3050-1929		●		●				15
	HV3050-2230			●	●				15
	HV3050-2234			●	●				15
	HV3050-1822H	●			●				15
	HV3050-2028H		●		●				15
	HV3060-3030			●	●				10
	HV3060-27G			●			●		10
	HV47-1835		●		●				10
	HV47-1925		●		●				10
	HV47-25M		●			●			10
	HV47-2235			●	●				10
43 × 35mm	HV170-25M	●				●			6
	HV170-2535H			●	●				6
	HV170-29M		●			●			6
	HV170-29ML		●			●			4
	HV170-25G		●				●		6
	HV170-29XH			●				●	6
扁型	HV5030-2522		●						4
	HV5030-1944		●		●				4



柄部直径φ22mm

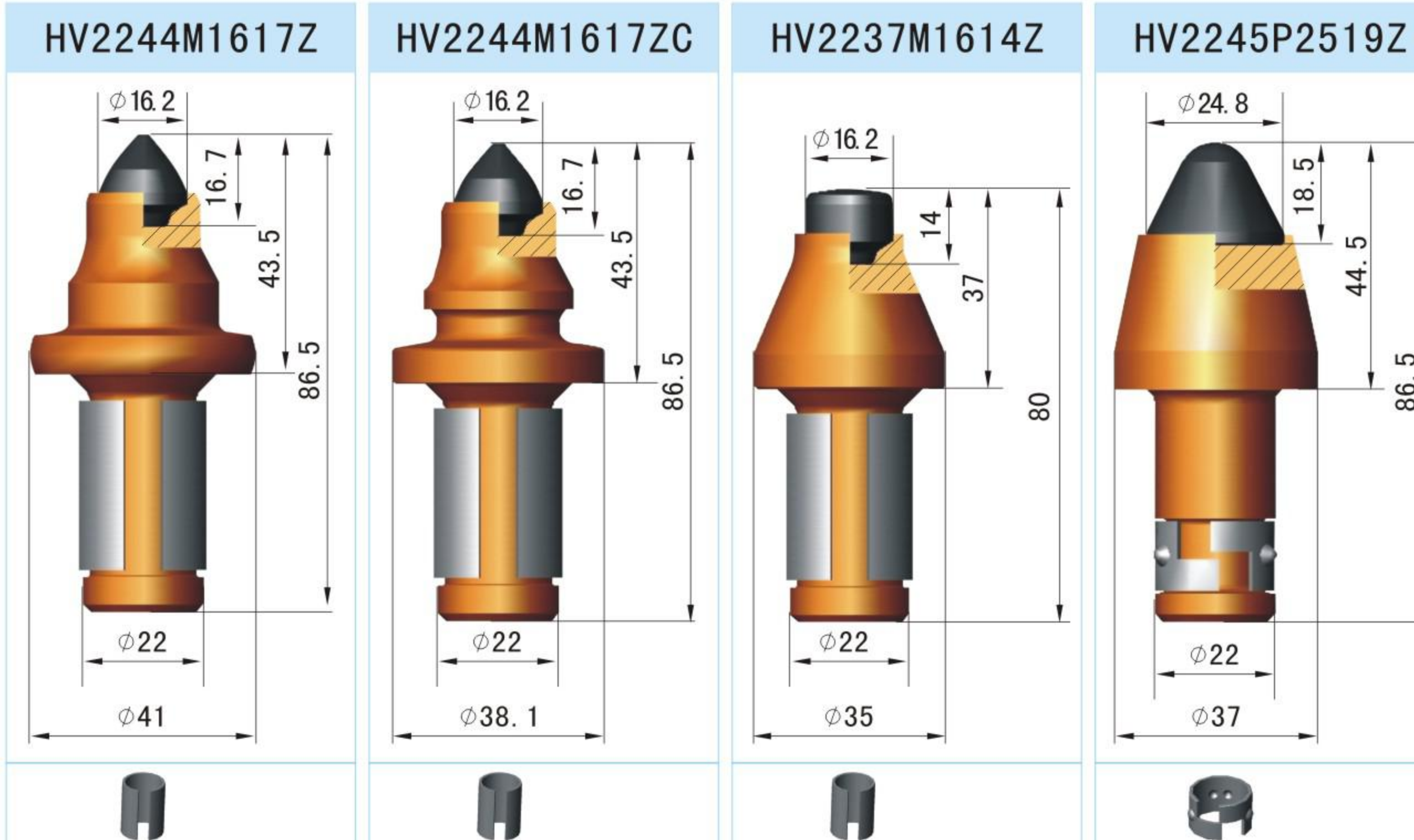

柄部直径φ25mm

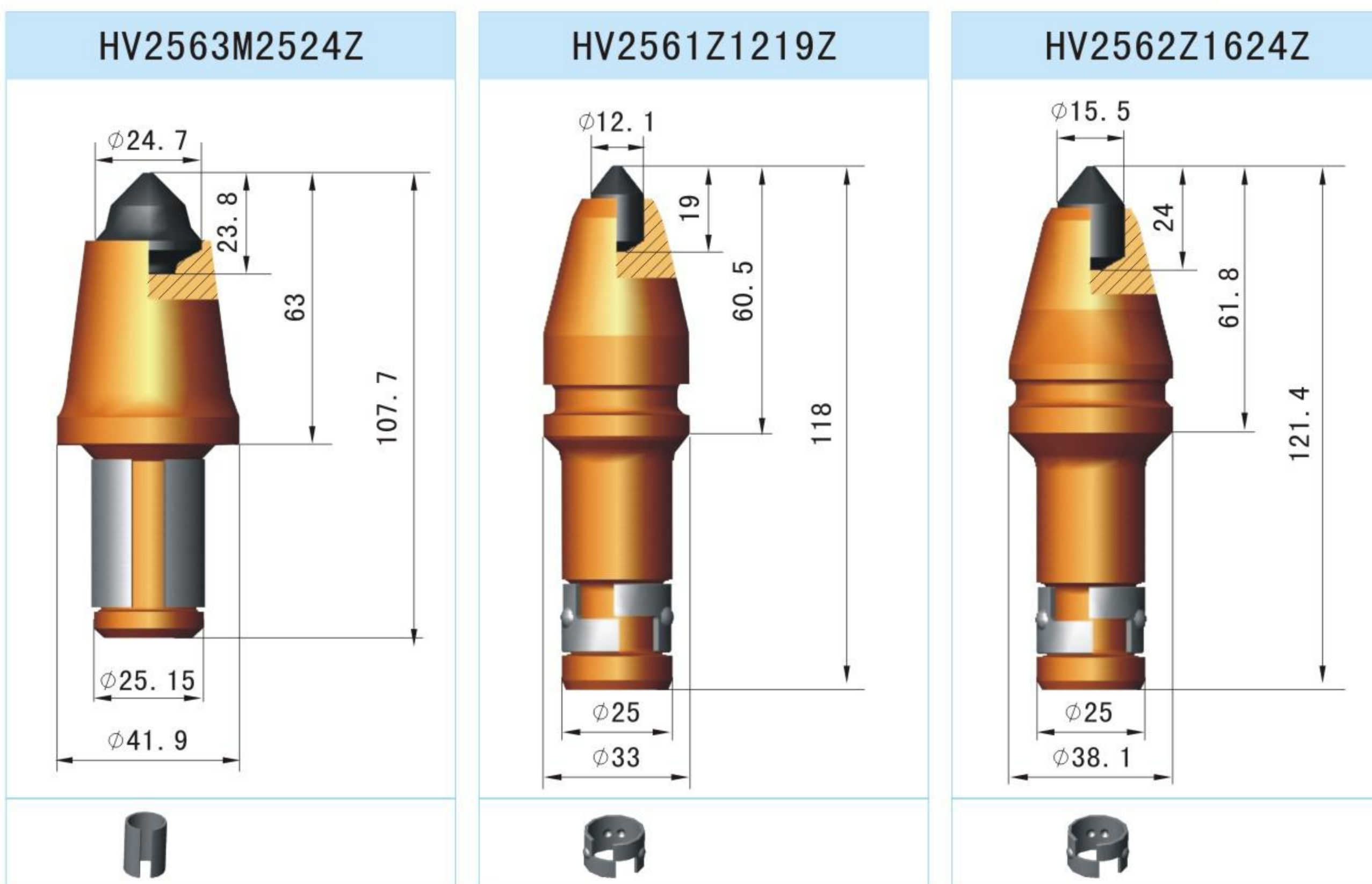

锥形截齿



柄部直径 $\phi 25\text{mm}$



HV2558Z1217X

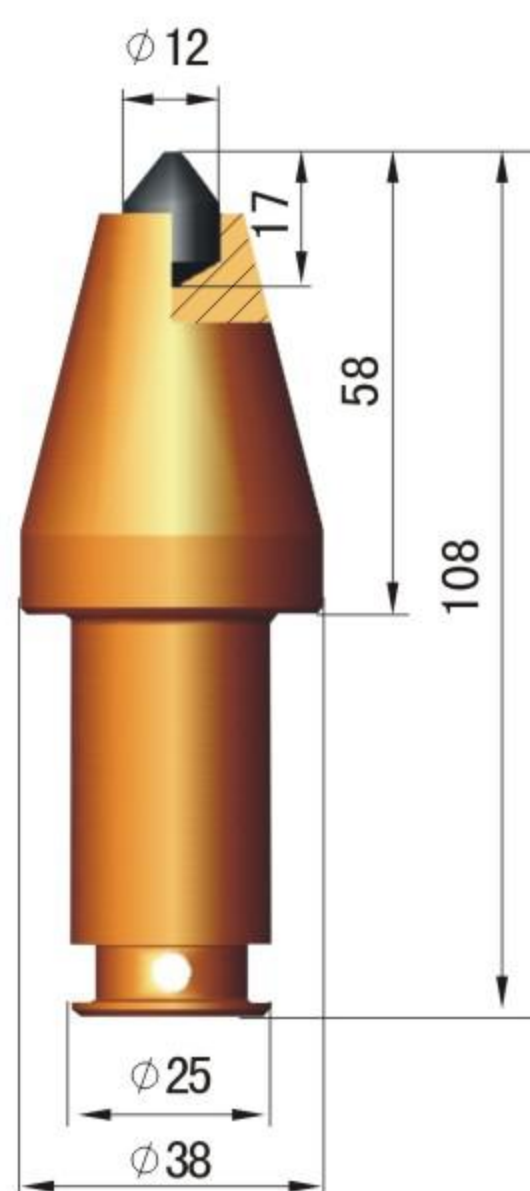

HV2558Z1322X

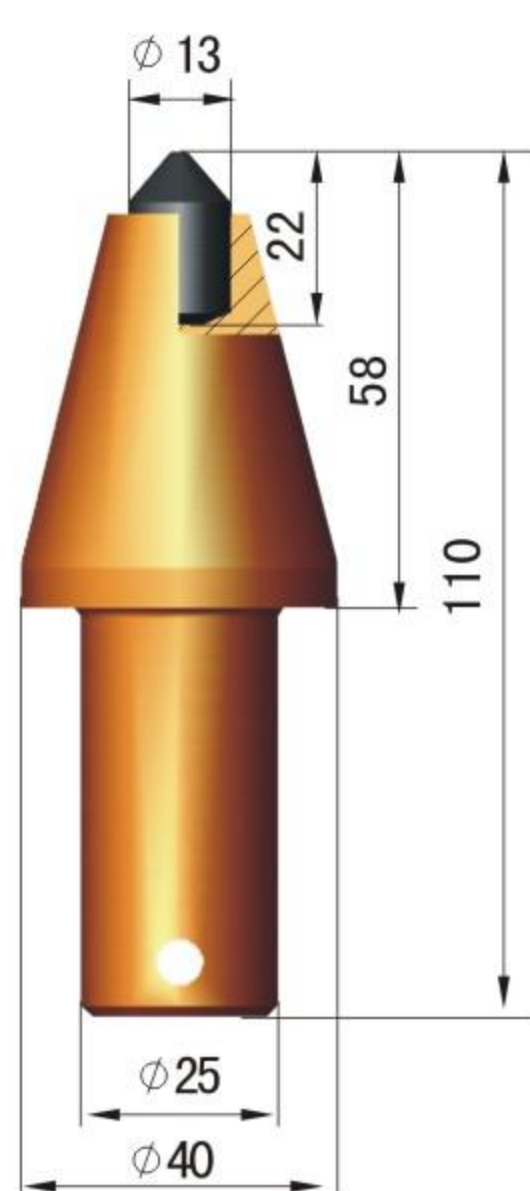

HV2567Z2235D

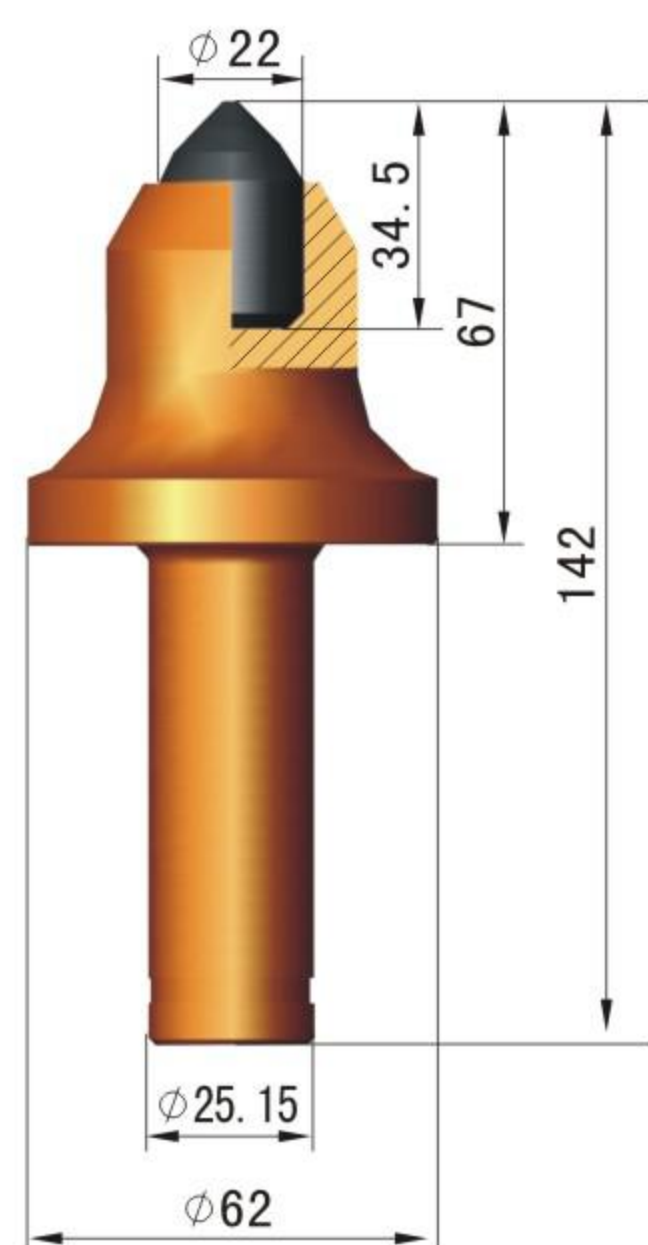

HV2565M2524D

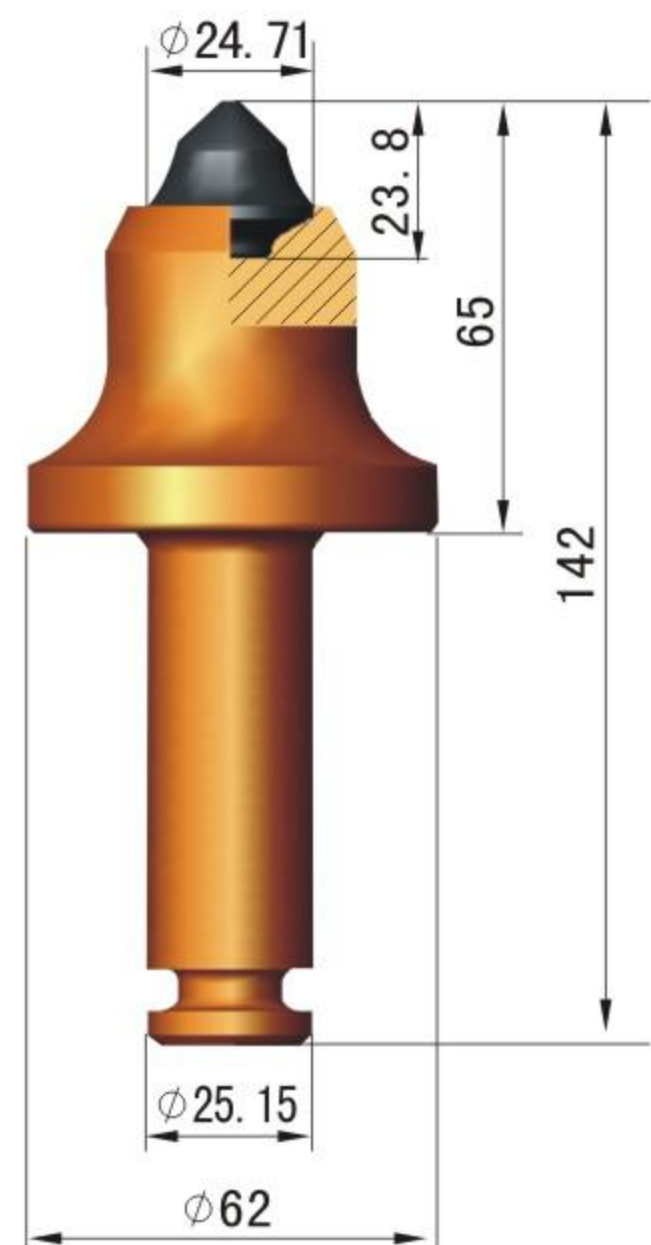

HV2567M2932D

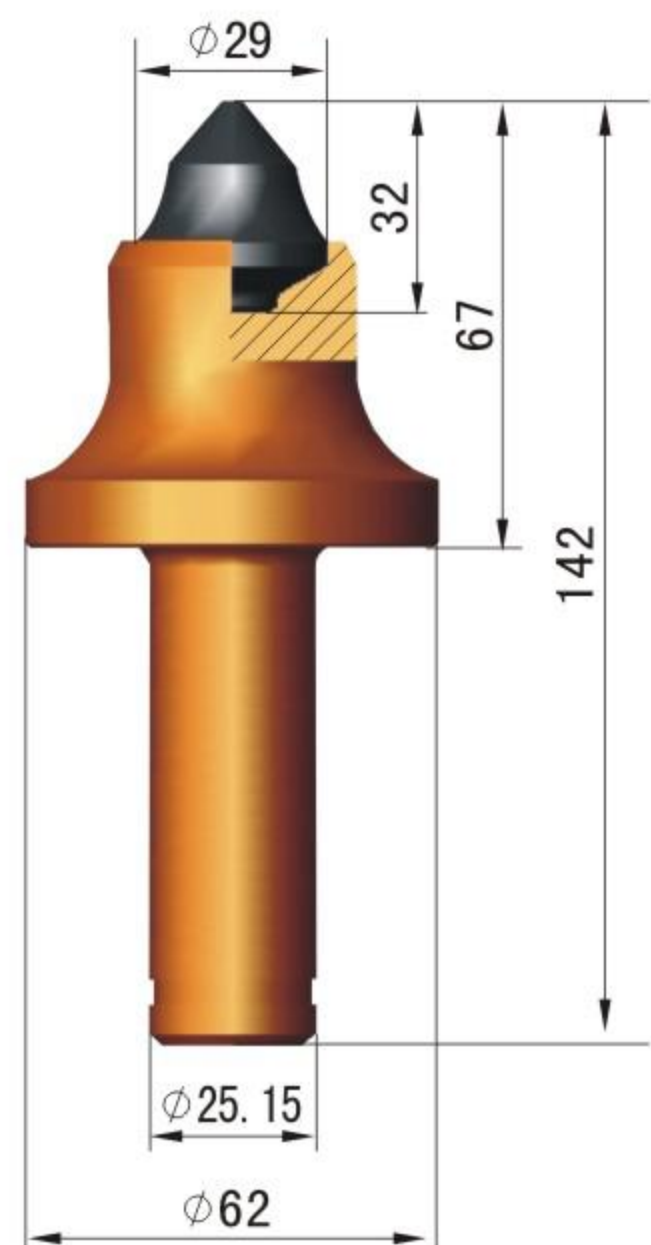

锥形截齿



柄部直径 $\phi 30\text{mm}$



HV120-19G

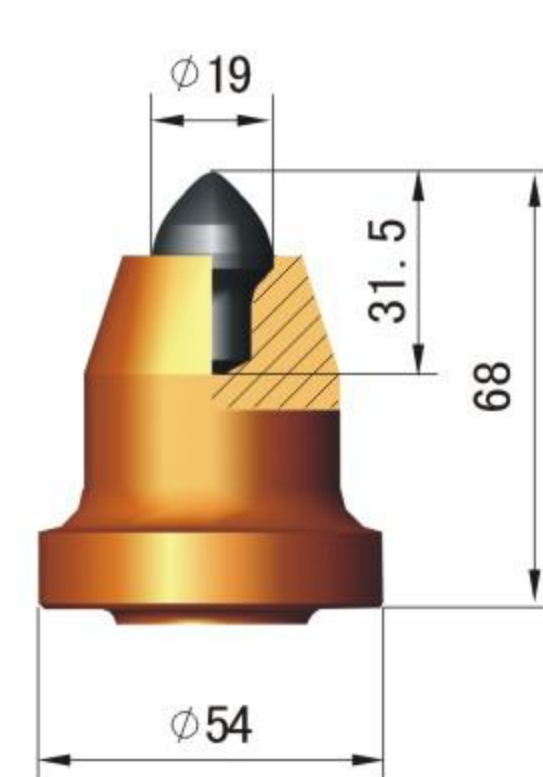

HV120-22G

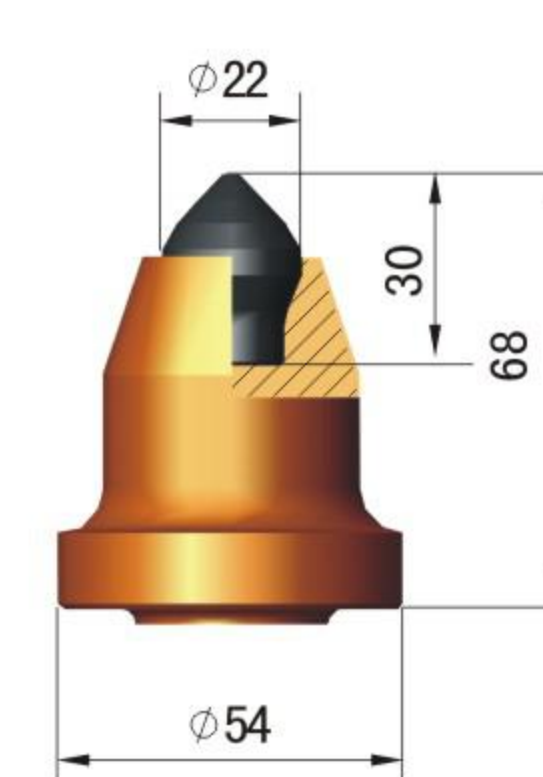

HV120-1824

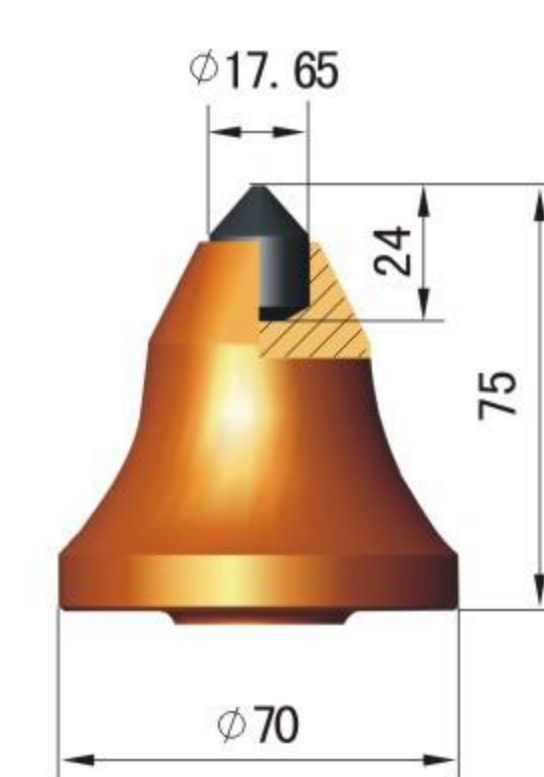

HV120-1929

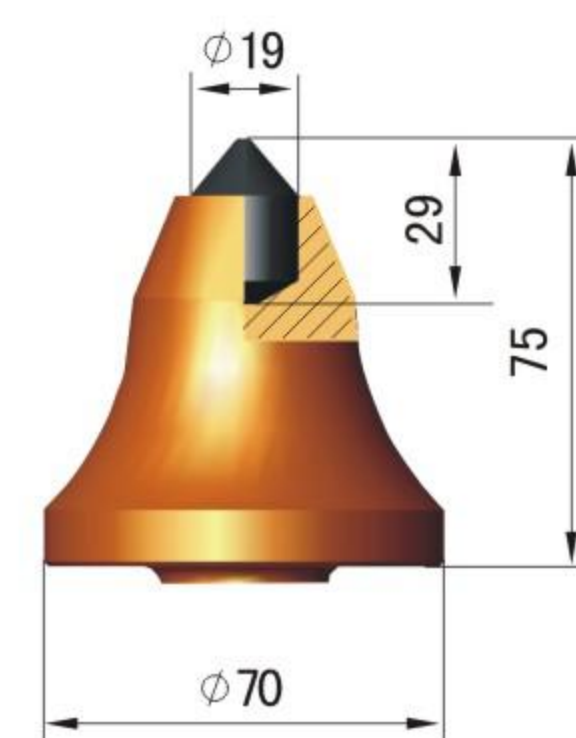

HV120-2230

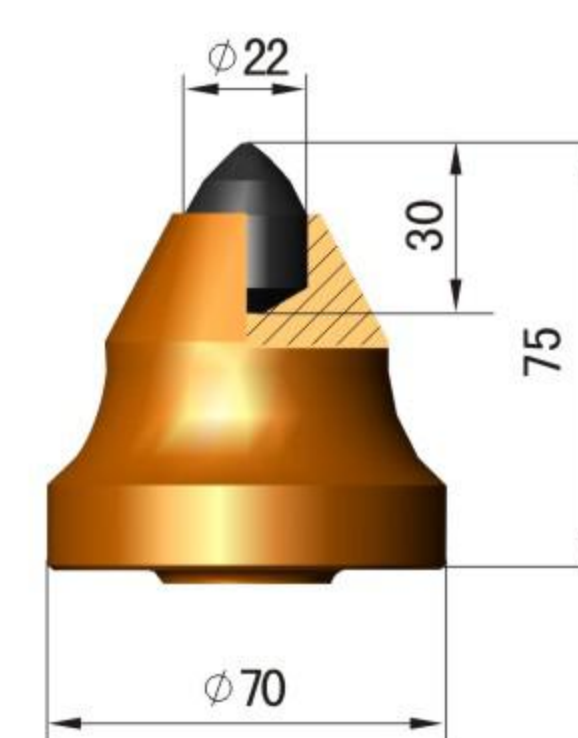

HV120-22GH

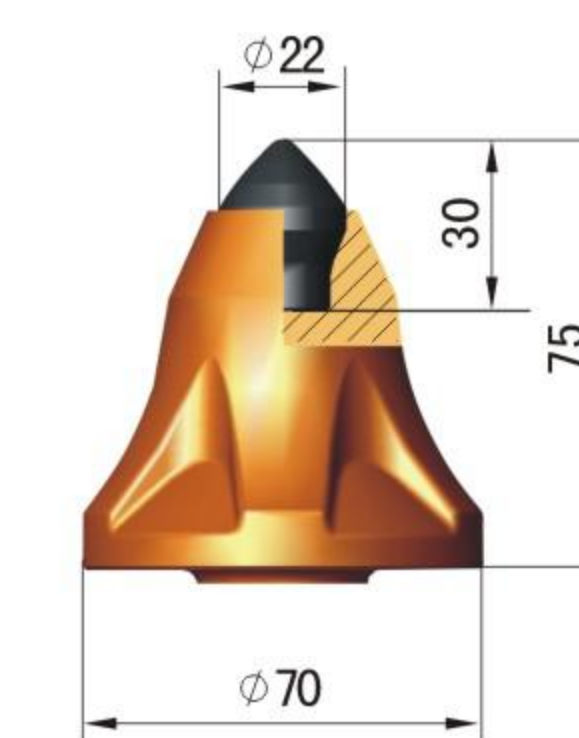

HV120-2535H

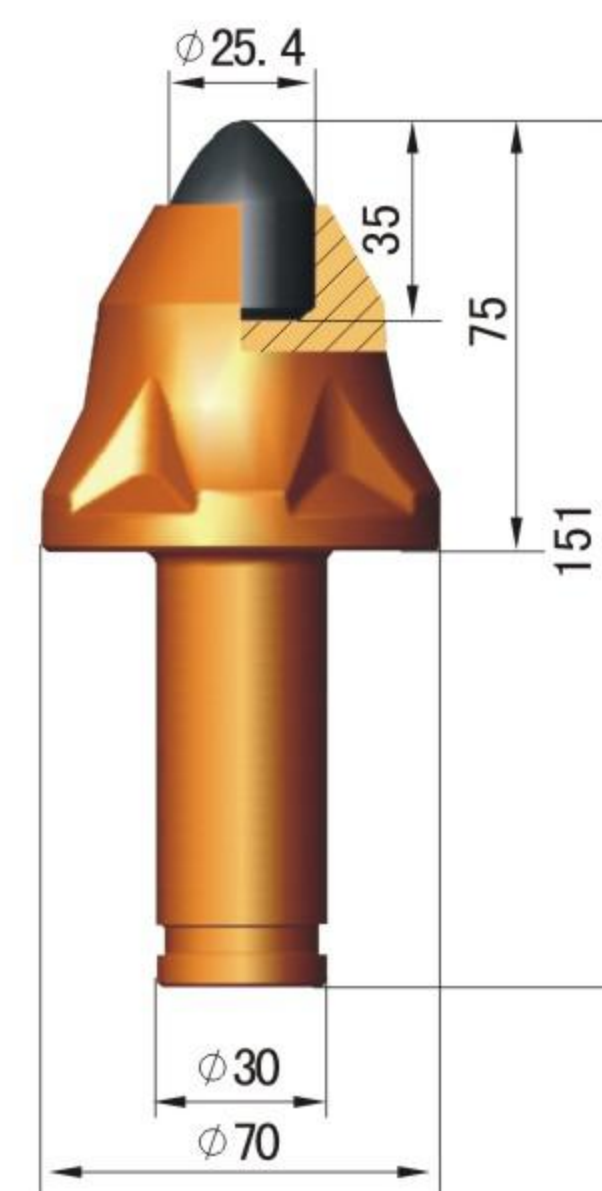

锥形截齿



柄部直径 $\phi 30\text{mm}$



HV82-14G

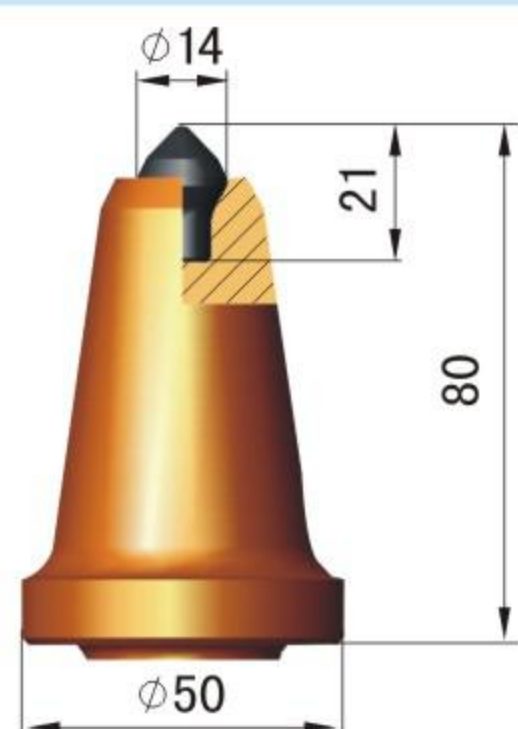

HV82-16G

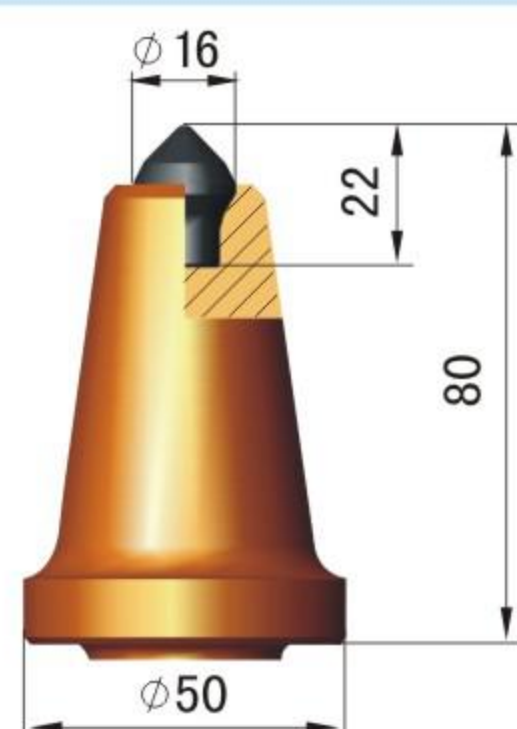

HV84-20XH

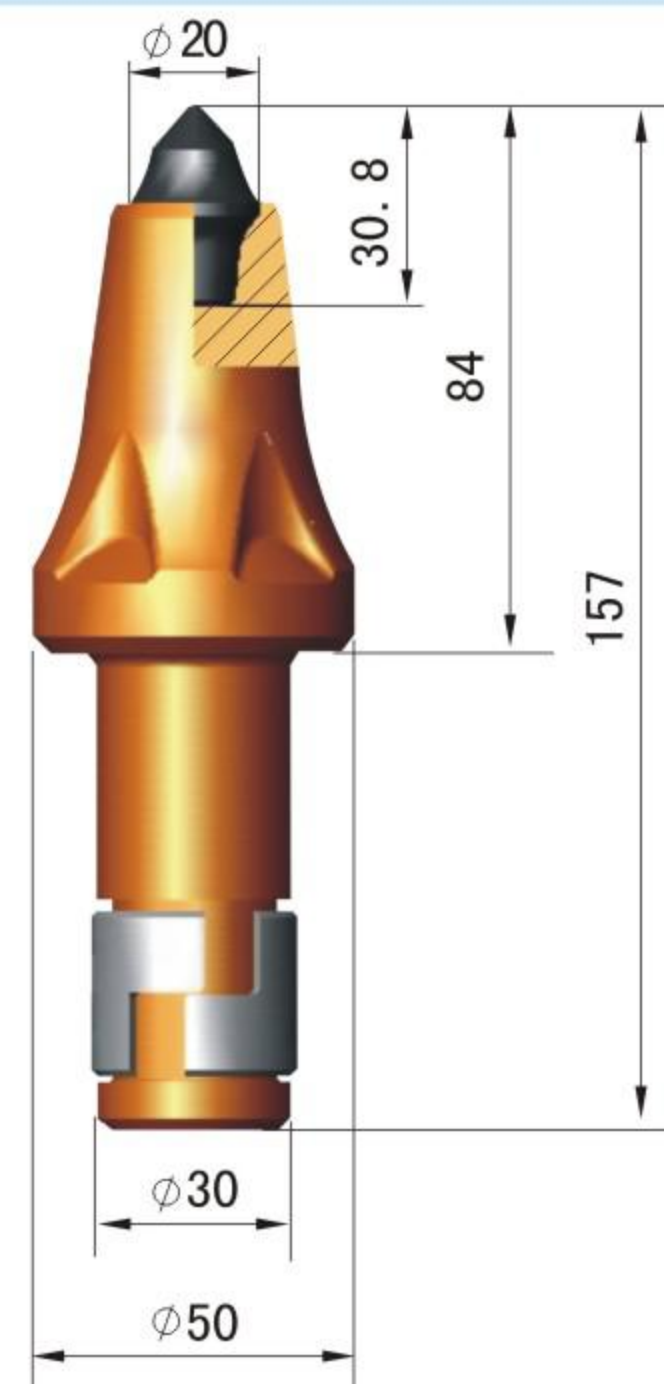

HV84-1829

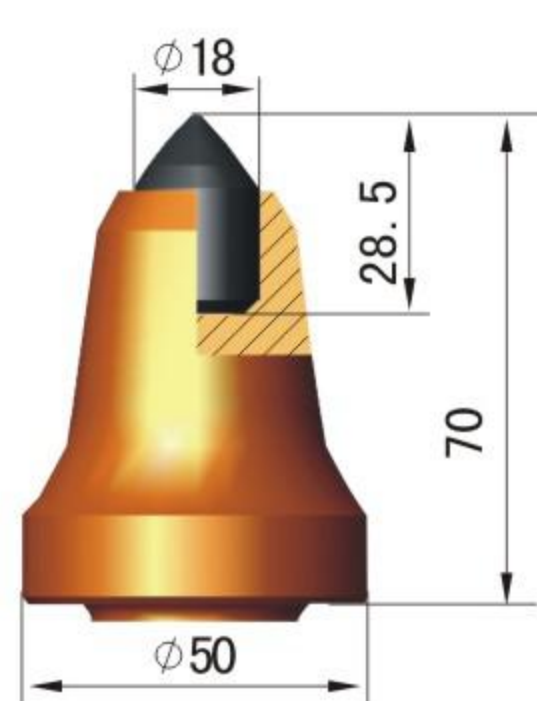

HV84-19G

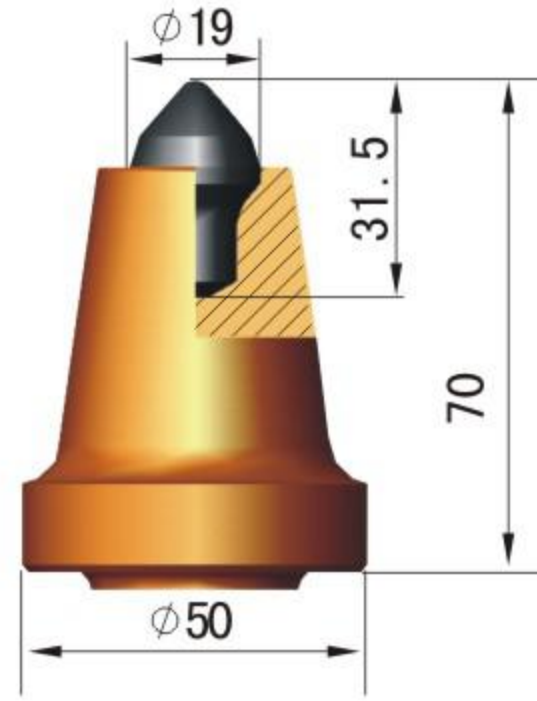

HV62-1622

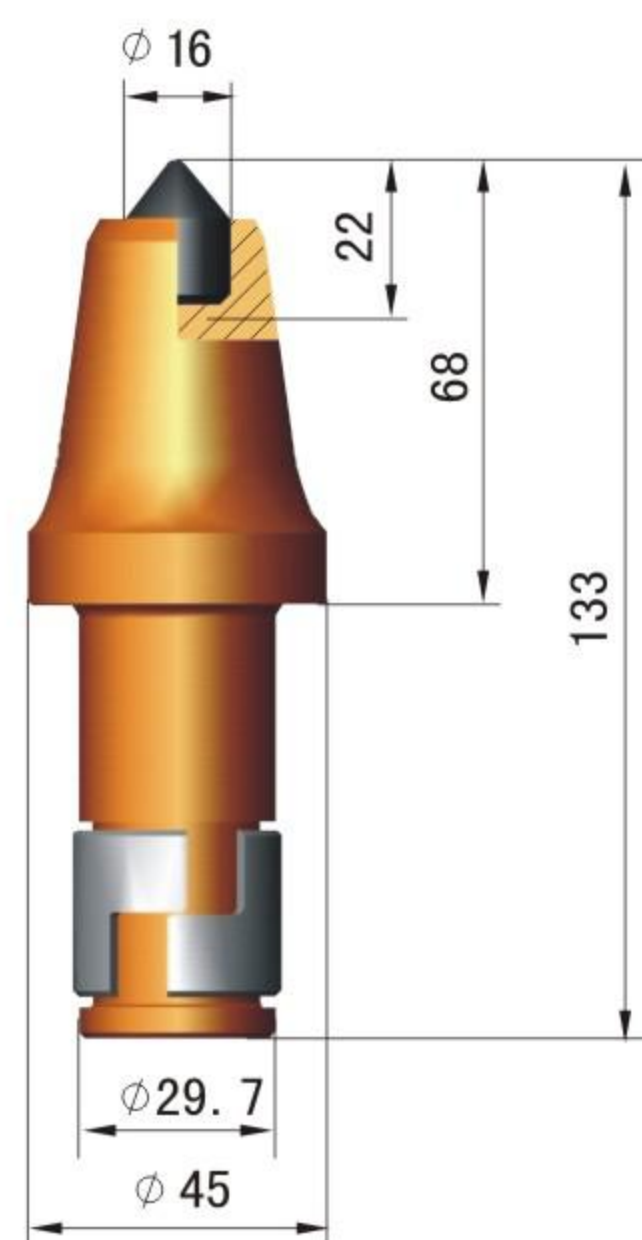

锥形截齿



柄部直径 $\phi 34\text{mm}$



HV100-19G

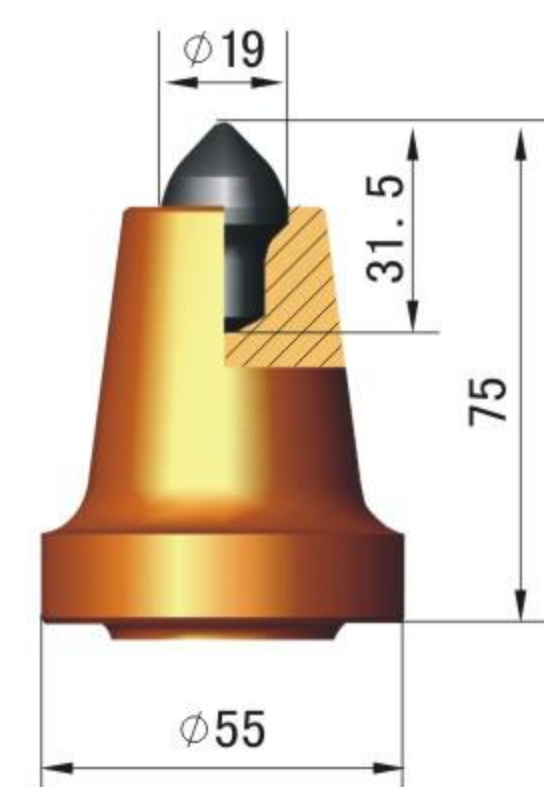

HV100-22G

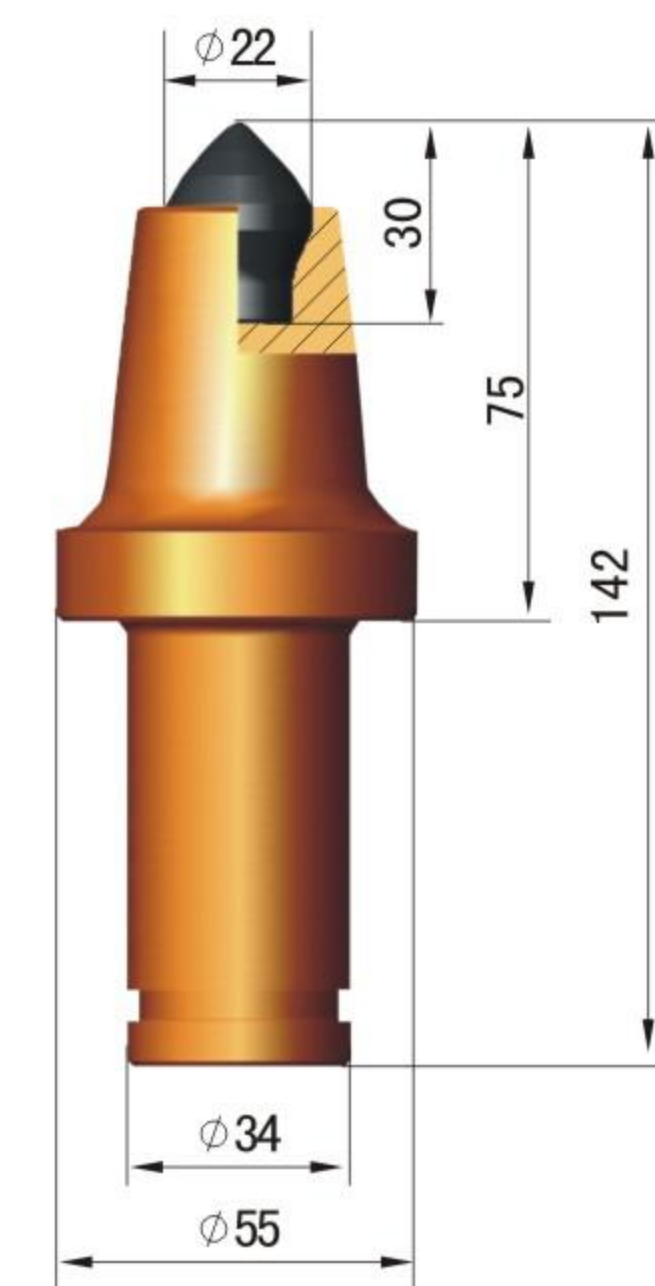

锥形截齿



柄部直径 $\phi 35\text{mm}$



HV92-16G

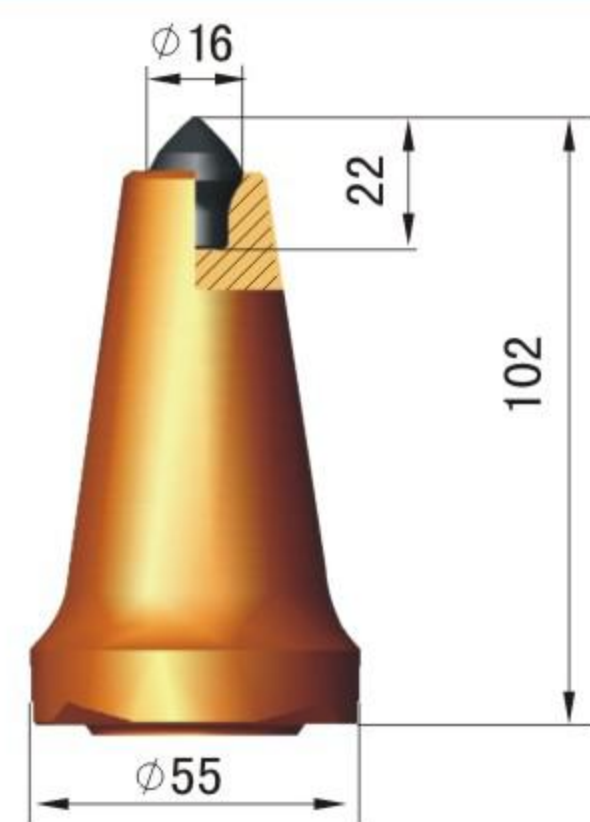

HV94-19G

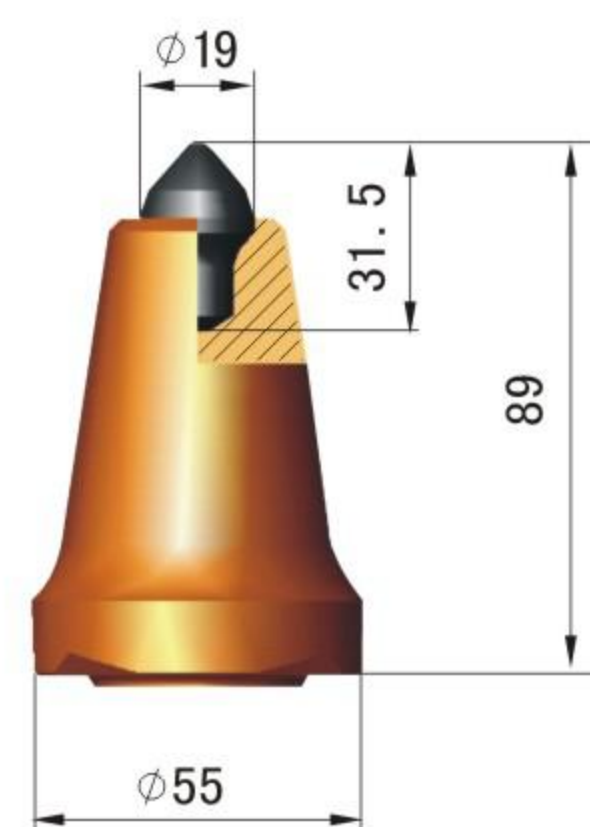

HV94-1925

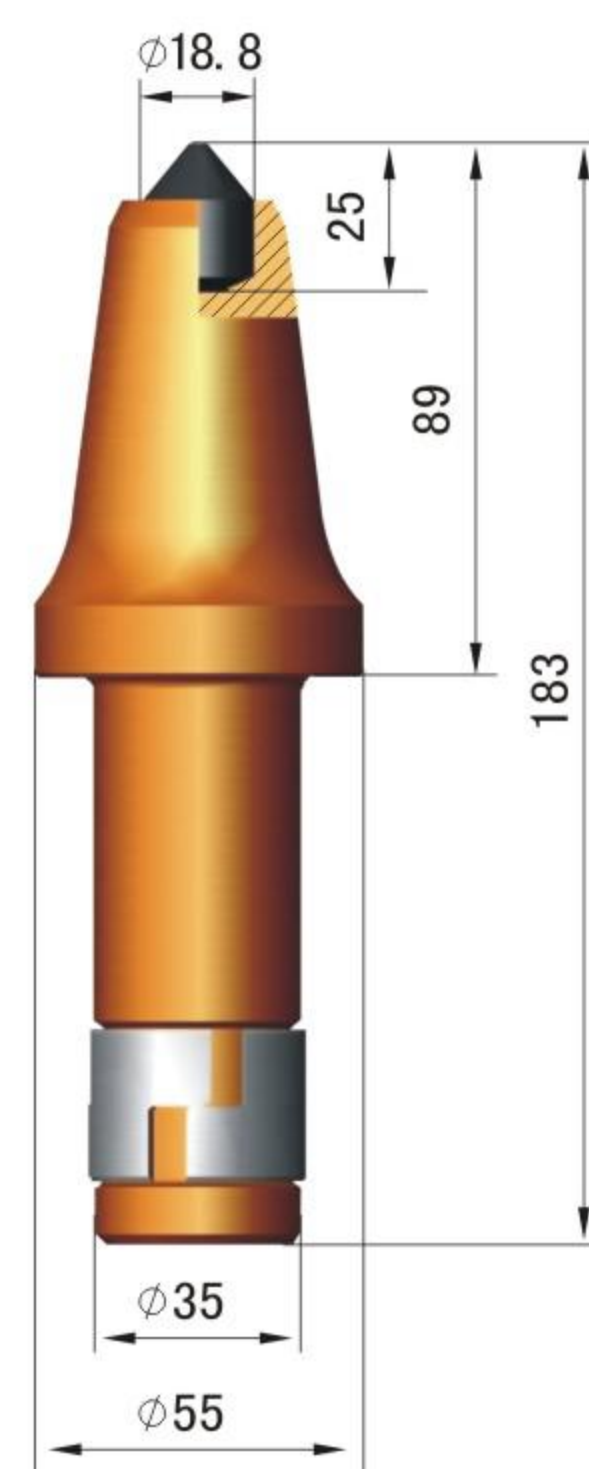

HV95-2535H

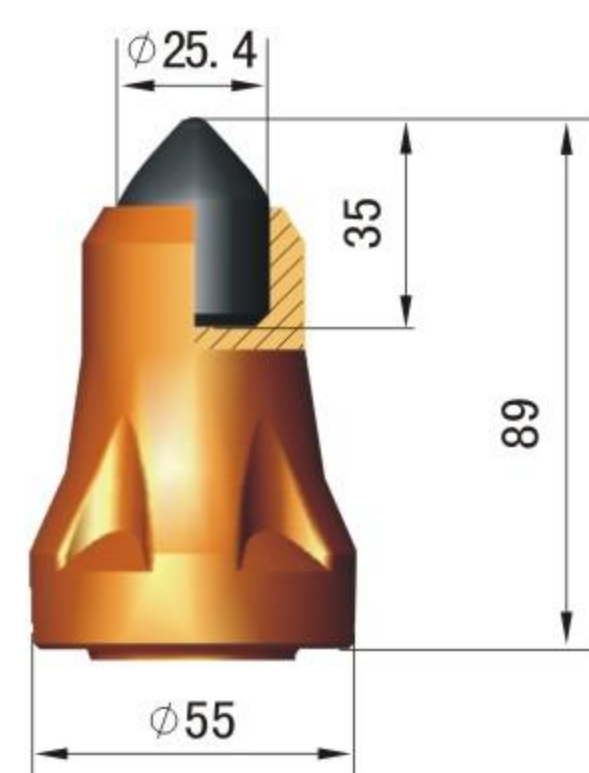

HV95-29XH

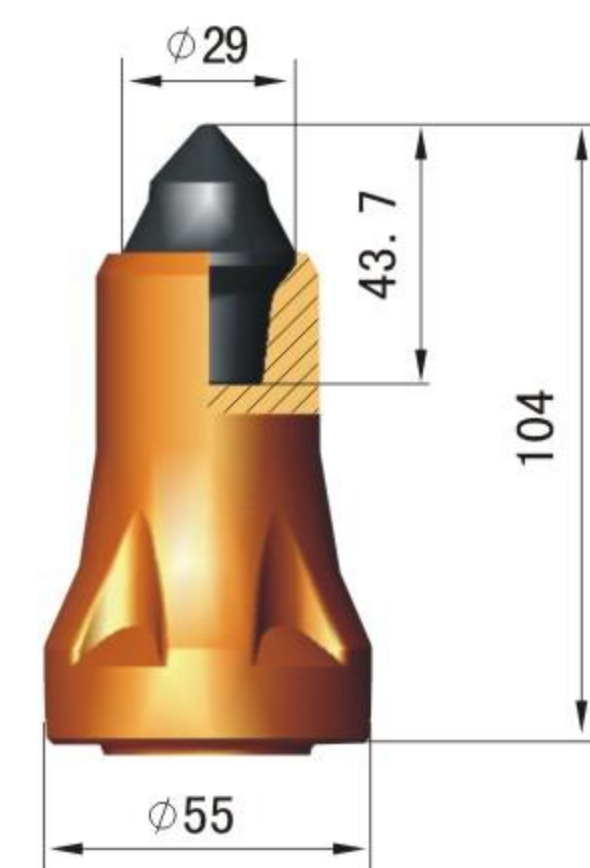

HV95-2535

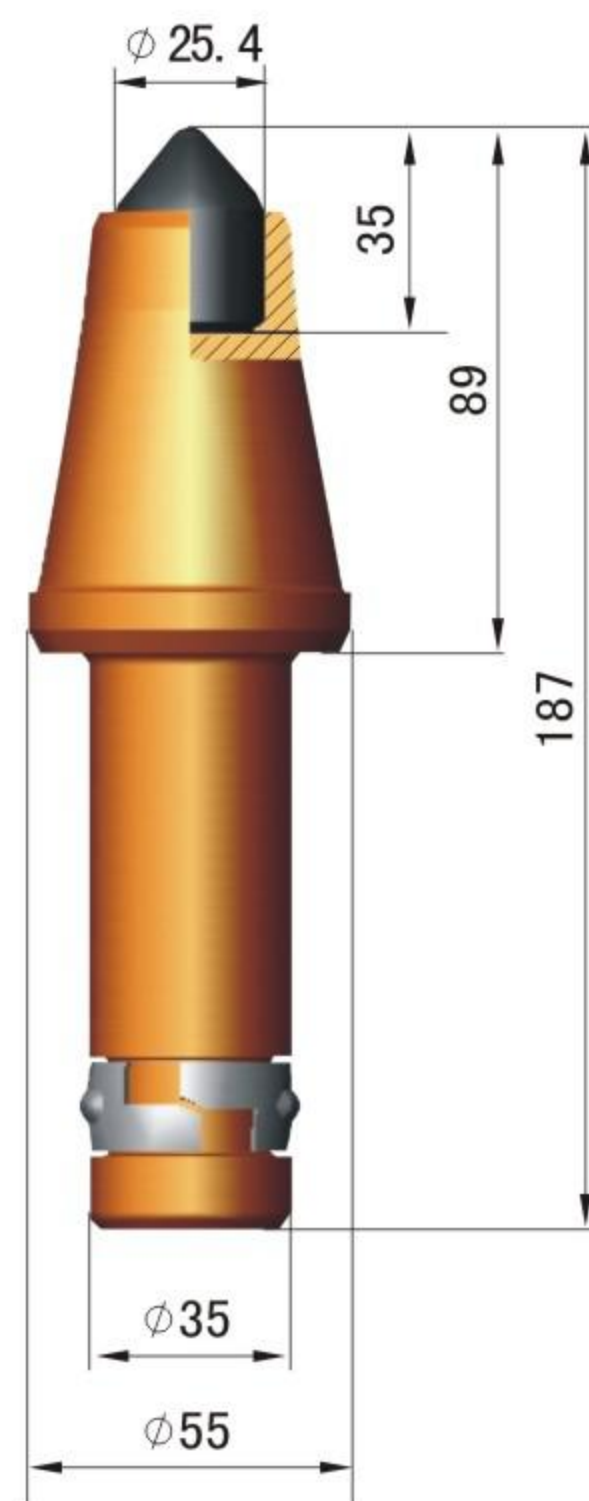

锥形截齿



柄部直径 $\phi 38\text{mm}$



HV135-22G

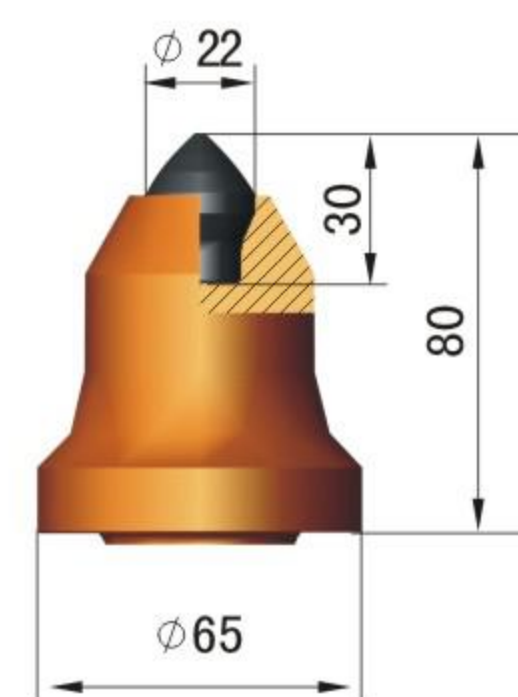

HV135-25G

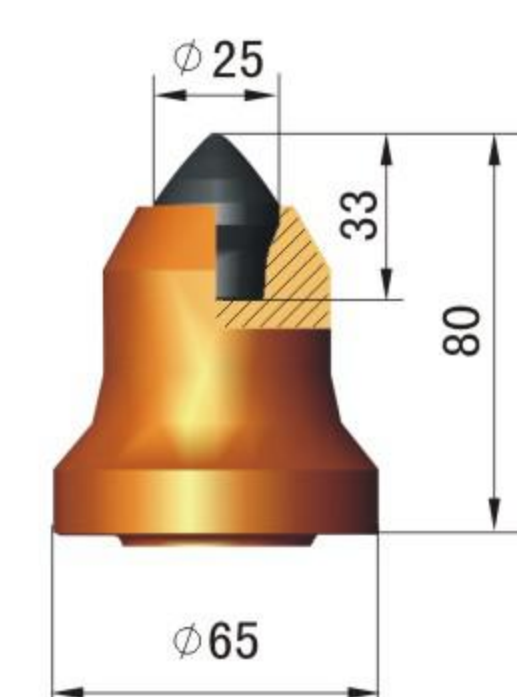

HV135M-29XH

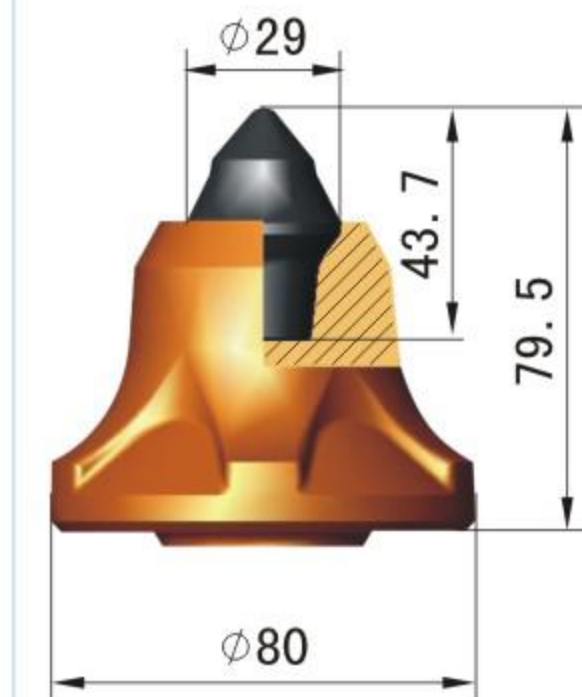

HV135-2535

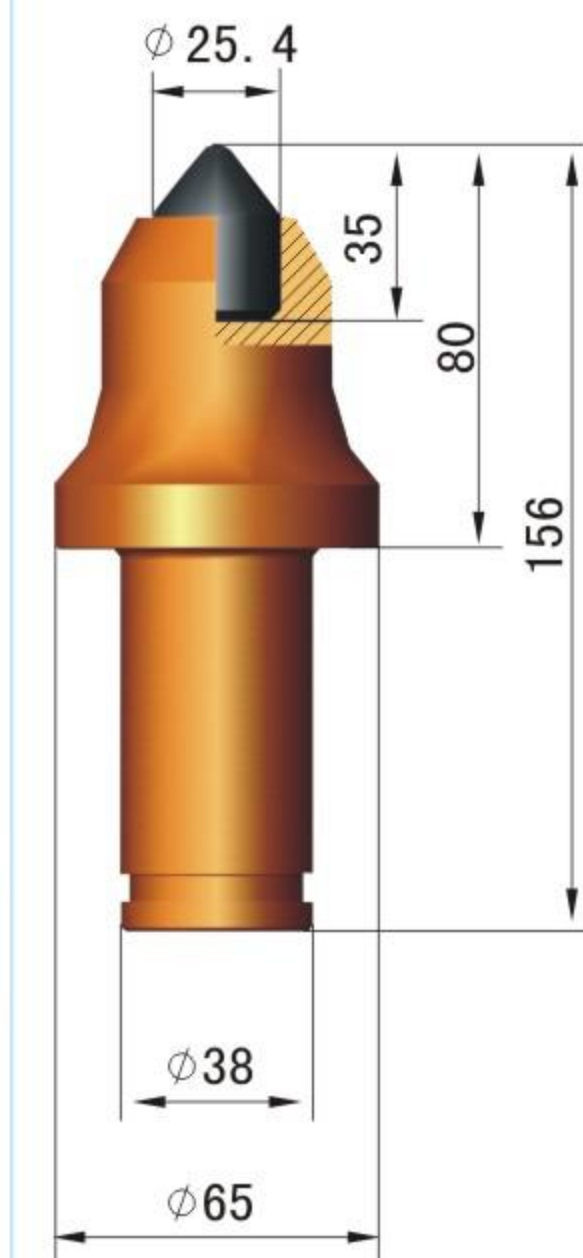

HV135M-3038H

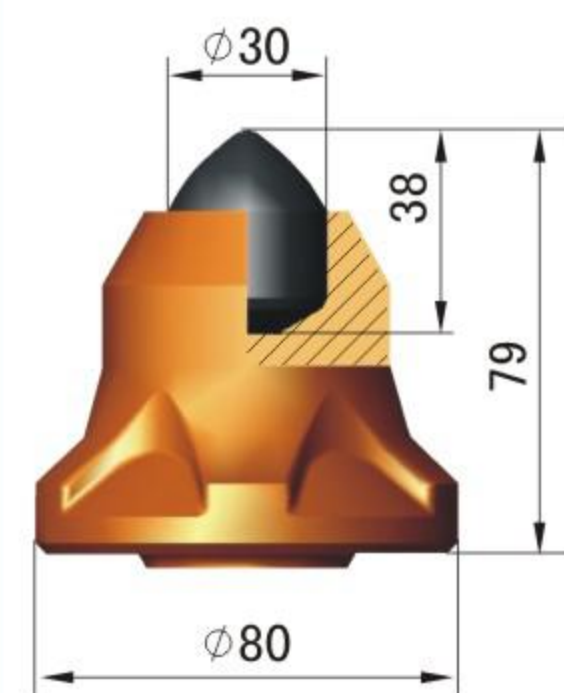

HVRC38-30

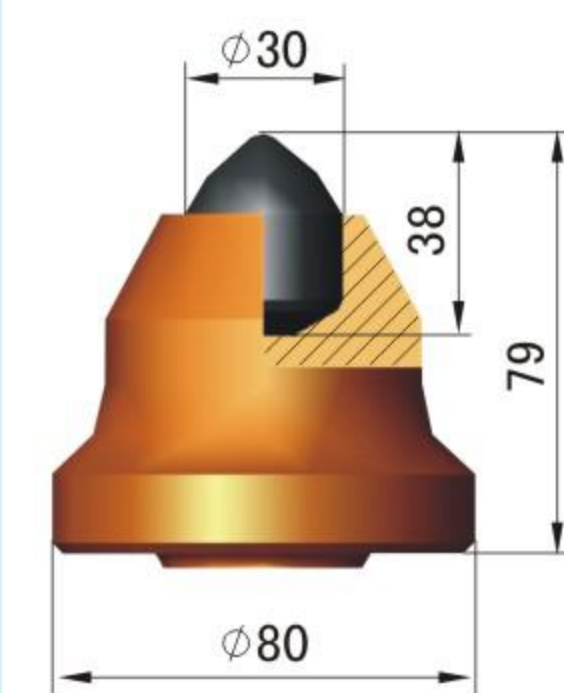

HCRC38-34

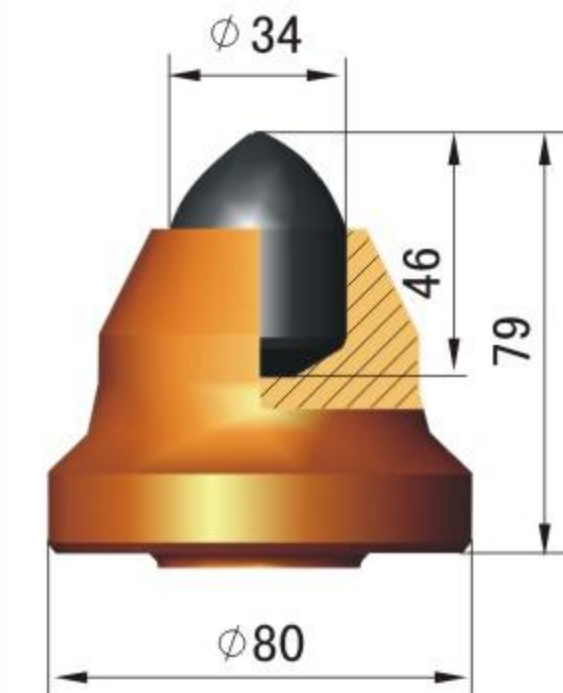

HV135-2535T

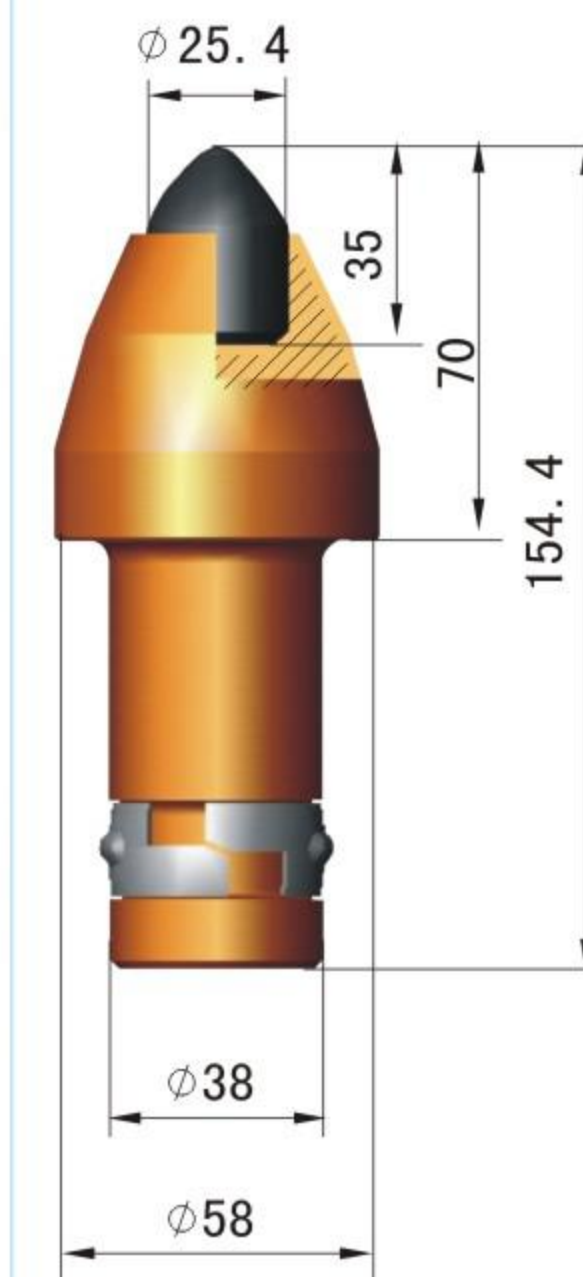

锥形截齿



柄部直径 $\phi 38 \times \phi 30\text{mm}$



<p>HV3050-1824</p>	<p>HV3050-1829</p>	<p>HV3050-1925</p>	<p>HV3050-1929</p>
<p>HV3050-2230</p>	<p>HV3050-2234</p>		
<p>HV3050-1822H</p>	<p>HV3050-2028H</p>		
<p>HV3060-3030</p>	<p>HV3060-27G</p>		

锥形截齿



柄部直径 $\phi 38 \times \phi 30\text{mm}$



<p>HV47-1835</p>	<p>HV47-1925</p>	<p>HV47-25M</p>	<p>HV47-2235</p>
-------------------------	-------------------------	------------------------	-------------------------



锥形截齿



柄部直径 $\phi 43 \times \phi 35\text{mm}$

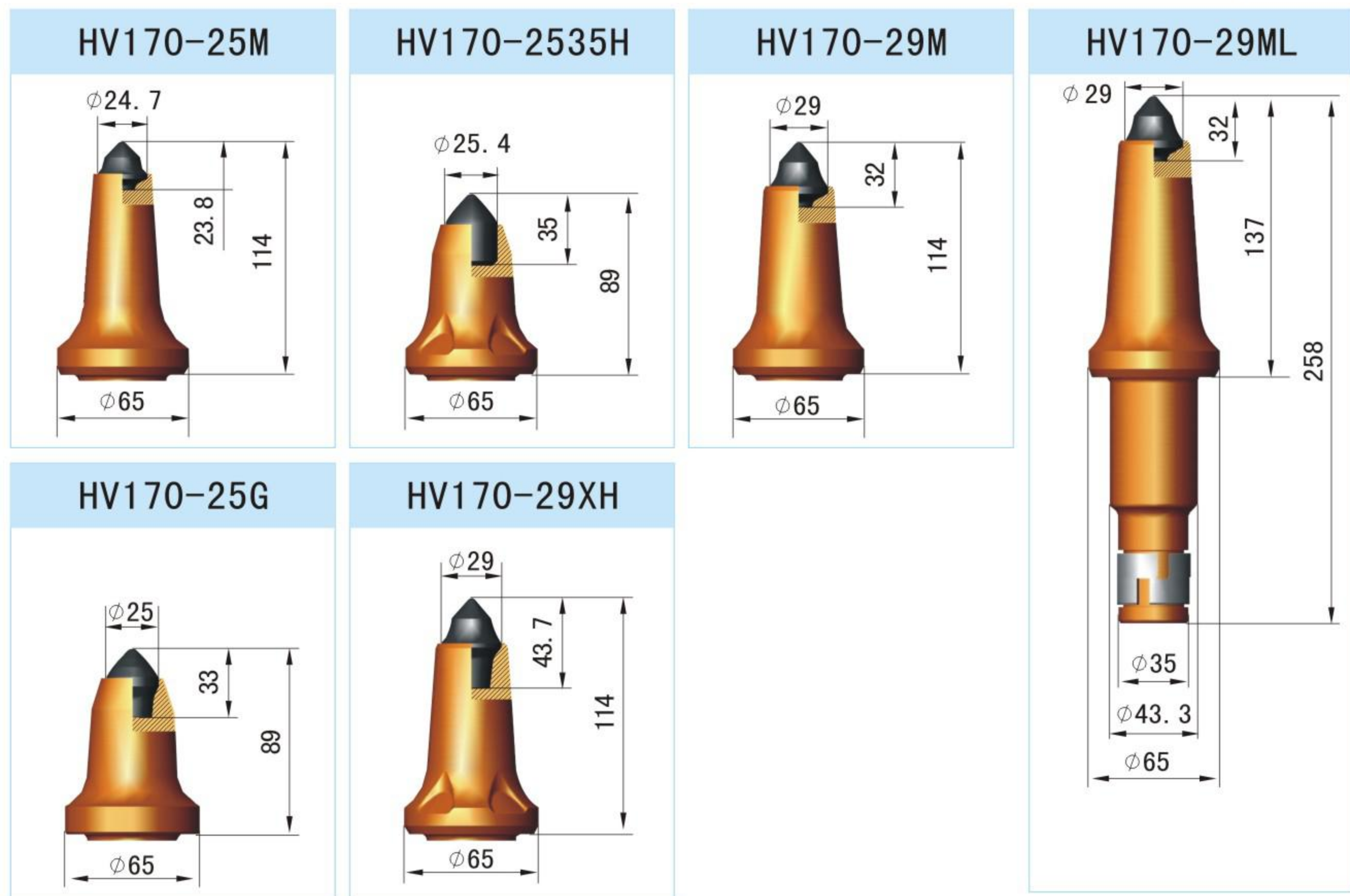

扁形截齿



HV5030-2522

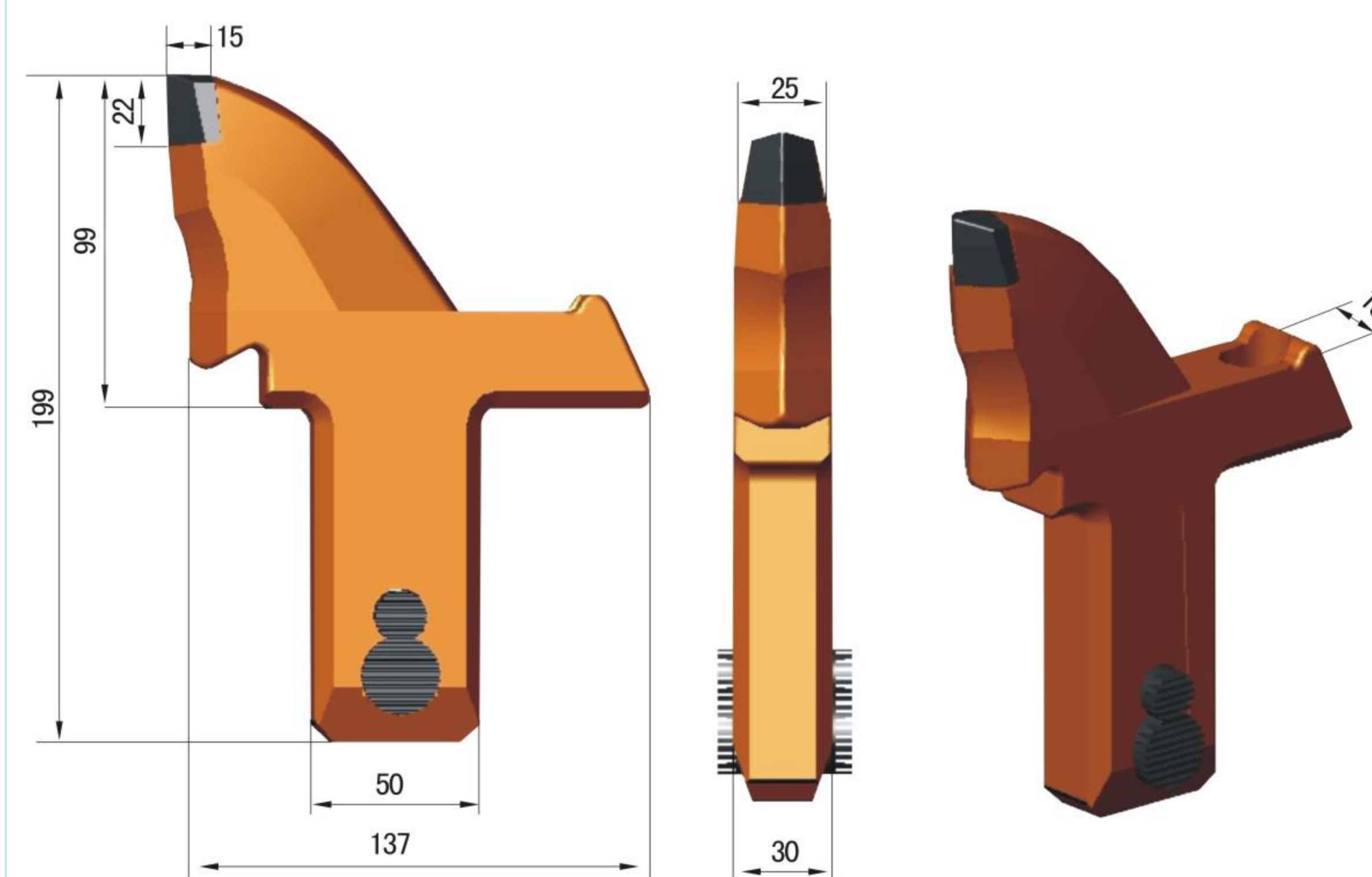

HV5030-1944

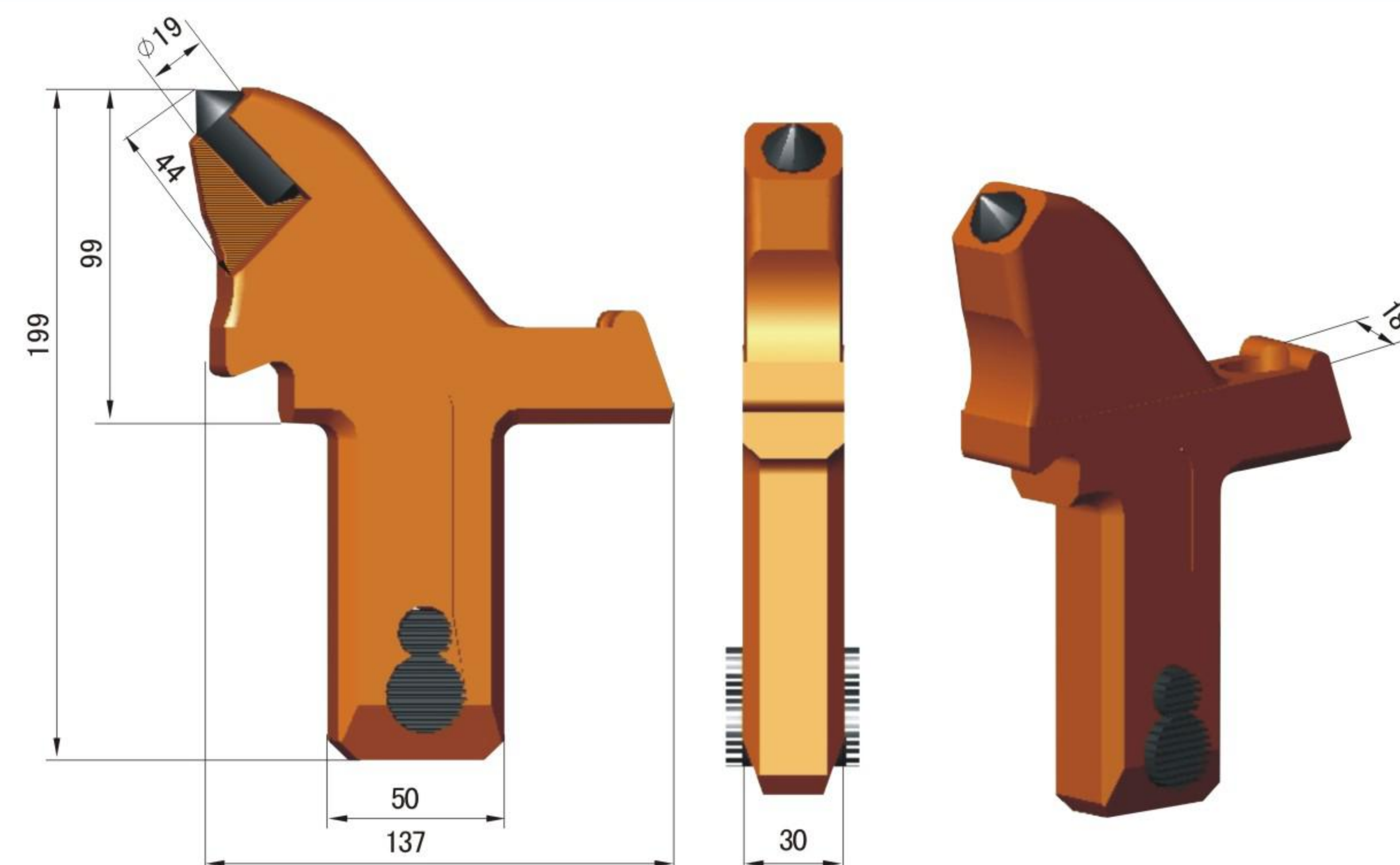

自硬公司保留对产品进行修改的权利。本目录中展示的产品并非采用1:1比例和原色彩。